

International Journal of Innovative Research in Science, Engineering and Technology

(A High Impact Factor, Monthly, Peer Reviewed Journal)

Visit: www.ijirset.com

Vol. 9, Issue 3, March 2020

An Efficient Hardware design of MED based Spectrum Sensor using VLSI architecture for Cognitive Radio

N. Elayabharathi¹, M. Poonguzhali²

Department of ECE, Narasu's Sarathy Institute of Technology, Salem, Tamil Nadu, India ^{1,2}

ABSTRACT: Cognitive Radio Network is an intelligent piece of machine which can be programmed and configured dynamically. It is an adaptive technology that can automatically detect the available channels in a wireless spectrum and change the parameters in the transmission, enabling us to communicate more effectively. In this paper, a Maximum Eigenvalue based Detection (MED) algorithm is used as a spectrum sensor for cognitive radio network. Our contributions focus on providing a hardware friendly MED based spectrum sensing algorithm. In addition, we propose a resource-shared VLSI architecture for this algorithm to enhance the efficiency of the hardware with low sensing time. A performance comparison is carried out between MED and cyclostationary based spectrum sensing algorithm. In that, MED based spectrum sensing algorithm delivered better performance than cyclostationary based algorithm at the detection probability of 0.5 based on the simulation result.

KEYWORDS: Cognitive Radio Network, Spectrum Access, Spectrum Sensing, Cognitive Radio User or Secondary User, Primary User, Maximum Eigen value based Detection.

I. INTRODUCTION

The Cognitive Radio (CR), a key technology for future wireless communication is capable of sensing and adapting to environments. The Cognitive Radio is an intelligent radio that can be programmed and configured dynamically [1]. The dramatic growth of wireless application and steadily increasing demands for higher quality of service have led to a perceived dearth of available radio bandwidth, which necessitates the search for more efficient utilization of spectrum resources[2][3]. In this paradigm the wireless nodes can sense the spectrum adapt the transmission/reception to the available spectrum, and dynamically share the spectrum with other applications. Cognitive Radio Networks (CRN) is encouraged by the apparent lack of spectrum under the current spectrum management functionalities. In order to address the critical problem of a spectrum scarcity FCC has recently approved the use of unlicensed devices in licensed bands.

The emergence of cognitive and software defined radio concepts, multiple antenna and multi carrier techniques as well as Ultra Wide Band (UWB) technologies and mesh network topologies provide a technology panacea that proponents of this approach used to support their arguments. CR network however, impose unique challenges due to the high fluctuation in the available spectrum as well as diverse quality of service (QoS) requirement [4]. CR technology is entirely build using Multihop ad hoc architecture which is shown in the Figure 1. A CR user can communicate with other CR users through Ad-Hoc connection on both licensed and unlicensed spectrum bands. Specifically, in CR adhoc networks (CRAHNS), the distributed multi-hop architecture, the dynamic network topology, and the time and location varying spectrum availability are some of the key distinguishing factors. These challenges necessitate novel design techniques that simultaneously address a wide range of communication problems spanning several layers of the protocol stack.

International Journal of Innovative Research in Science, Engineering and Technology

(A High Impact Factor, Monthly, Peer Reviewed Journal)

Visit: www.ijirset.com

Vol. 9, Issue 3, March 2020

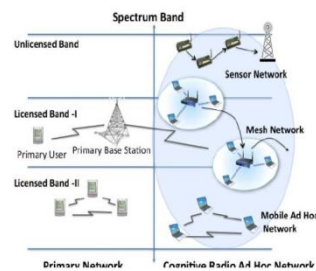

Fig. 1.1 CRAHN

The ultimate objective of the cognitive radio is to obtain the best available spectrum through cognitive capability and re-configurability as described before. Since most of the spectrum is already assigned, the most important challenge is to share the licensed spectrum without interfering with the transmission of other licensed users as illustrated in Fig. 2. The cognitive radio enables the usage of temporarily unused spectrum, which is referred to as spectrum hole [5]. If this band is further utilized by a licensed user then cognitive radio moves to another spectrum hole or stays in the same band, altering its transmission power level or modulation scheme to avoid interference as shown in the Fig 2.

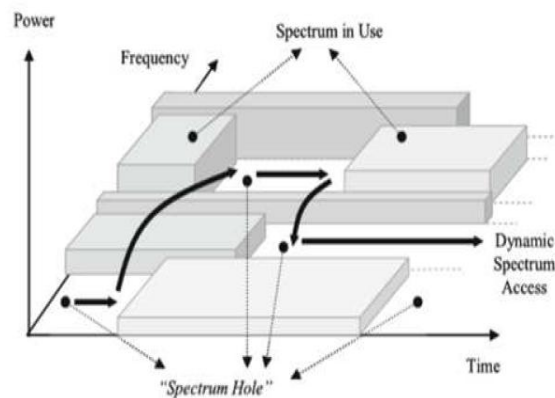

Fig.1.2 Spectrum Hole concept

In our paper, it discusses about Spectrum sensing function of the cognitive radio network. Spectrum sensing is a feature of detecting unused spectrum and sharing it, without harmful interference to other users. An important requirement of cognitive radio network is the ability to sense the empty spectrum. To accomplish that detecting the primary users is the most efficient way to detect the empty spectrum. Spectrum sensing techniques are grouped into Transmitter detection, Wideband spectrum sensing and Null-space based CR. C.Nagarajan et al [3,7,11] proposed the transmitter detection methods and ways to enhance it are discussed. There are three approaches used in transmitter detection they are

1. Matched Filter Detection
2. Energy Detection and
3. Cyclostationary feature detection.

International Journal of Innovative Research in Science, Engineering and Technology

(A High Impact Factor, Monthly, Peer Reviewed Journal)

Visit: www.ijirset.com

Vol. 9, Issue 3, March 2020

Many Algorithms have been discussed in papers for the same viz. energy, cyclostationary and matched-filter detections based spectrum sensing algorithms (SSAs) [6]. Matched filter based SSA requires more and complete knowledge of PU for detection [6]. Similarly, cyclostationary SSA needs frequency of PU or cyclic prefix and on the other hand, energy detection demands noise-variance for reliable detection and has lower implementation complexity [7][8]. However, energy detection is only the most suited for uncorrelated signals whereas it delivers degraded performance for correlated signals. [9], after running through many scenarios concluded that energy detection based spectrum sensing is not suitable for real-world scenarios. Cyclostationary detection based SSA delivers good performance for highly correlated signals at lower SNR at the cost of higher hardware complexity and sensing time [7],[10]. Hence this challenge needs to be resolved by designing a new spectrum sensor with more efficient hardware which provides better performance even in worst-case channel condition (in negative SNR region).

In the paper written by Zeng et al. [11] proposed maximum eigenvalue (of statistical co-variance matrix of received signals) detection (MED) based SSA and has demonstrated better performance when comparing to energy detection based SSA for correlated signals.

Eventhough many number of Eigenvalue based SSA's have been mentioned in the literature, its VLSI implementation contributions are in sparse. In literature [12,13], the maximum and minimum eigen values are calculated using jacobi method implemented in frequency domain. A drawback found in this method is that it has higher hardware-complexity and it calculates all the eigenvalues (whereas only maximum and minimum eigen values are required). As far the search goes, there is no information found w.r.t to work for VLSI architecture of MED based spectrum sensor for CRN applications.

In our paper a hardware friendly MED based SSA is suggested and further more resource sharing technique has been used in our sensor architecture to enhance the hardware efficiency. In addition, a performance comparison of cyclostationary based SSAs using orthogonal frequency division multiplexing (OFDM) modulation scheme in additive-white Gaussian-noise (AWGN) channel condition and MED has been presented in our paper. The proposed architecture is application-specific integrated-circuits (ASIC) synthesized and postlayout simulated in 90 nm-CMOS process. Hence, the results are compared with state of the art spectrum sensors and our proposal shows that it has better sensing time and better hardware efficiency compared to other implementations. Once the channel is sensed the Secondary User needs to reconfigure itself to sensed frequency channel resulting into additional delay called switching delay [14]. Hence switching delay overhead includes sensing time. In order to get good results switching delay should be reduced as low as possible.

II. PRELIMINARIES

Detection of signal in Spectrum sensing is fundamentally a binary hypothesis testing problem there the hypotheses H_0 and H_1 indicates the absence and the presence of PU as represented below.

$$\begin{aligned} H_0 : x[n] &= \eta[n], \\ H_1 : x[n] &= h[n] \cdot s[n] + \eta[n] \end{aligned} \quad (1)$$

Where $n=\{1, 2, 3, \dots, N_s\}$ where N_s is the total number of samples used for detection, $s[n]$ is signal sample of PU, $\eta[n]$ is noise sample, $h[n]$ is frequency-flat channel and $x[n]$ is the received sample/observation.

In this testing problem, the computation of test statistics value $\Gamma(\cdot)$ is carried out based on the recorded observations and finally, it is compared with the standard decision threshold value γ to decide the presence/absence of PU

$$\{\text{i.e. } \Gamma(x[n] \forall n = 1, 2, \dots, N_s) \leq_{H_1}^{H_0} \gamma\}$$

International Journal of Innovative Research in Science, Engineering and Technology

(A High Impact Factor, Monthly, Peer Reviewed Journal)

Visit: www.ijirset.com

Vol. 9, Issue 3, March 2020

The MED based spectrum sensing algorithm delivers the optimized best probability of detection (P_d) for highly correlated received signal samples where it first computes the auto-correlation of these samples $x[n]$ as

$$\lambda(l) = \frac{1}{N_s} \sum_{m=0}^{N_s-1-l} x^*[m] \cdot x[m-l], \quad \forall l = \{0, 1, \dots, L-1\} \quad (2)$$

Where L is the smoothing/Lag factor. Subsequently, the statistical co-variance matrix of such auto-correlated values are constructed as

$$\hat{R}_x(N_s) = \begin{bmatrix} \lambda(0) & \lambda(1) & \dots & \lambda(L-1) \\ \lambda^*(1) & \lambda(0) & \dots & \lambda(L-2) \\ \vdots & \vdots & \ddots & \vdots \\ \lambda^*(L-1) & \lambda^*(L-2) & \dots & \lambda(0) \end{bmatrix}. \quad (3)$$

This is Toeplitz matrix where maximum eigen value is obtained in MED algorithm and it is the test statistics. In addition, a decision threshold is precalculated with noise variance as below and compared with maximum eigen value in order to indicate the absence or presence of PU's.

$$\gamma = \frac{(\sqrt{N_s} + \sqrt{L})^2}{N_s} \left(1 + \frac{(\sqrt{N_s} + \sqrt{L})^{-2/3}}{(N_s \cdot L)^{1/6}} \right) F^{-1}(1 - P_{fa}) \quad (4)$$

where F^{-1} is the cumulative distribution function (CDF) of the Tracy-Widom distribution of order 1 and P_{fa} represents the probability of false alarm.

III. PROPOSED MODEL

A. Hardware efficient MED Algorithm

In MED algorithm, the Maximum Eigen value computation is the key factor to perform the operation. There are various methods used to obtain Eigen value, but this method has very high implementation complexity [15], whereas MED SSA requires only maximum Eigen values. On the other side, an iterative power method mentioned in lit [16] computes only the required maximum Eigen value and its implementation is much easier. In this paper, we have improved iterative algorithm for hardware efficient implementation.

B. Proposed VLSI Architecture of MED based Spectrum Sensor

Originally, the EM waves received at the antenna is RF converted, band-pass filtered, low noise amplified and converted into base-band signals which subsequently fed to ADC. Later it generates Quadrature (Q) and inphase (I) signal components of each sample $x[n]$ which is given to MED based spectrum sensor for further processing to detect the presence or absence of the Primary Users. In this paper, each of these I/Q samples from ADC are taken to be 14 bits each and thereby the quantization of input $x[n]$ to our sensor which is 28 bits.

The proposed arch of the MED based spectrum sensor has 3 major modules:

1. Autocorrelation computation module (ACM)
2. Covariance-matrix formation module (CFM)
3. Maximum-Eigen value computation module (MECDM).

ACM and CFM Architectures:

As mentioned in the earlier section – II, we need to compute the auto-correlation values $\lambda(l)$ from the received N_s signal samples, as presented in (2). Here the auto-correlation values $\lambda(l) \quad l = \{0, 1, 2, \dots, L-1\}$ can be computed in parallel. Since value of $L = 8$, increasing value of L has better performance with increase in area in our design, eight

International Journal of Innovative Research in Science, Engineering and Technology

(A High Impact Factor, Monthly, Peer Reviewed Journal)

Visit: www.ijirset.com

Vol. 9, Issue 3, March 2020

multiply and accumulate units MAC 1 – 8 are used where each mMAC unit comprises of 28-bits multiplier and 40 – bits adder as shown in Fig 1 (a). The input $x[n]$ to ACM is complex where 14 bits are assigned to real and other 14 bits to imaginary part of this signal. Conjugate computation module CCM determines the complex conjugate of $x[n]$ and is one of the inputs MAC units shown in Fig 1 (a). Registers are used for delaying the input samples and then fed to MAC unit as another input. Once each $\lambda(l)$ is calculated, it is multiplexed without waiting for the computation of other $\lambda(l)$ values and is divided using shifter which right shifts 10-bit places to realize the division by N_s (N_s considered as 1024), as shown in (2). Finally, de-multiplexer (DeMUX) steers these $\lambda(l)$ values one-by-one to CFM for the row formation of covariance matrix, as shown in Fig. 1 (a).

The complete covariance matrix from (3) is generated by CFM, that produces $L=8$ elements for each row and there are eight rows, as shown in Fig. 1 (b). From the second row onwards, we need to compute the conjugates of $\lambda(l)$ from the matrix in (3) and each conjugate is performed using CCM. All the $\lambda(l)$ values for each row of covariance matrix that is generated by CFM are concatenated as 8×28 bits and are fed as each input of the 8:1 multiplexer shown in Fig. 1 (b). Based on the select line of this multiplexer, all the elements of each row are generated in subsequent clock cycles.

C. MECDM VLSI-Architecture

The output 8×28 bits of CFM been distributed as 8 inputs of 28 bits each and are fed to maximum Eigen value computation.

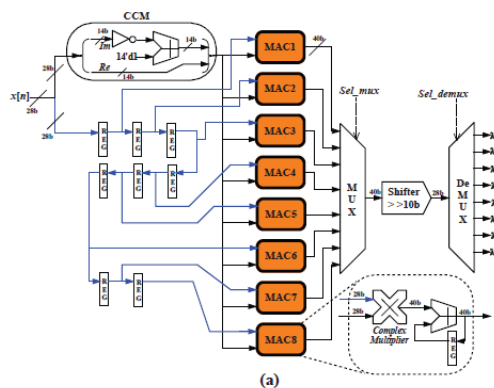

Fig. 1. (a) Proposed VLSI architectures of auto-correlation computation module (ACM)

International Journal of Innovative Research in Science, Engineering and Technology

(A High Impact Factor, Monthly, Peer Reviewed Journal)

Visit: www.ijirset.com

Vol. 9, Issue 3, March 2020

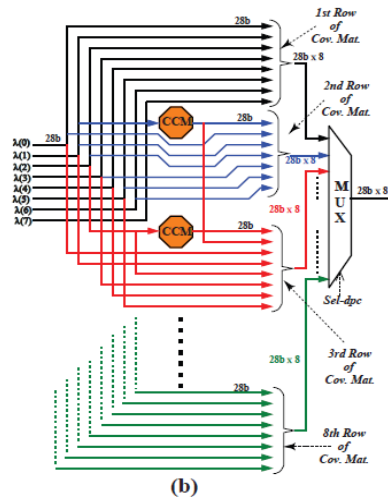

Fig. 1. (b) covariance-matrix formation module (CFM)

Detection module MECDM as shown in Fig 2 has been designed for the proposed MED algorithm. The dot product circuit DPC of this MECDM computes the matrix vector multiplication where the input to this multiplied with the feedback vector which is initialized with value one. Rows in covariance matrix is proportional to smoothing factor L and to process each row in parallel, DPCs are required. This results in large area overhead as each DPC requires complex multipliers L and L-1 complex adders. Therefore for parallel processing with L=8, 64 28 bit complex multipliers and adders are required. Proposed system have hardware efficiency has been enhanced by resource sharing single DPC module L times as shown in Fig 2.

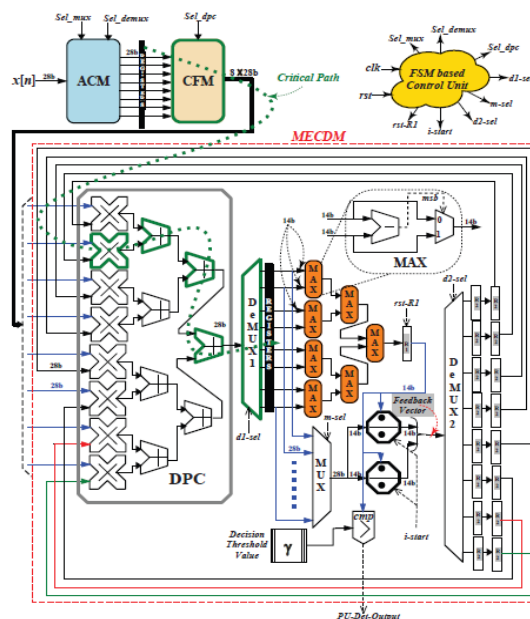

Fig. 2. Proposed VLSI architecture of MECDM and overall MED based spectrum sensor that integrates MECDM with ACM and CFM.

International Journal of Innovative Research in Science, Engineering and Technology

(A High Impact Factor, Monthly, Peer Reviewed Journal)

Visit: www.ijirset.com

Vol. 9, Issue 3, March 2020

Input to max computation module is streamed through the DEMUX. The output of DEMUX is fed to the MAX modules which sorts the input and provides the maximum among the inputs. The control signals for activating the register has been obtained from the control circuitry. Similarly the feedback vector is computed by dividing the output of DPC with the max value obtained from the max calculation module. There are two dividers are designed based on the iterative shifts and subtract method to divide 14-bits real term and 14-bits complex term, as shown in Fig 2. Divider output is registered at the output of DEMUX till the last DPC output is divided. Till then the same feedback vector value is maintained using register R2 and once all the DPC outputs are divided the registered value at the DEMUX output are activated to generate new feedback vector to DPC module. This process is repeated for no of iterations. Finally, the test statistics value is compared with the pre-computed decision threshold value γ value which indicates the presence or absence of Primary users as shown in Fig 2.

D. Sensing Time Analysis

Sensing time of our spectrum sensor depends on the total number of clock cycles (Γ_{clk}) required to compute the maximum Eigenvalue of the covariance matrix and further generate the detection output by comparing with γ . Specifically, the sensing time (τ_{sen}) also depends on the maximum clock frequency (ν_{max}) and this time is given as $\tau_{sen} = \Gamma_{clk} / \nu_{max}$. The total number of clock cycles consumed by ACM and CFM is $\Gamma_{ac} = (N_s - L - 1) + (L - 1) = N_s - 2$. Similarly for DPC and divider modules are $\Gamma_{dpc} = L \times I$ and $\Gamma_{div} = (20 \times L) I$, respectively, where I represents number of iterations and 20 indicates the number of shifting required for the division. The total number of clock cycle is

$$\Gamma_{clk} = \Gamma_{ac} + \Gamma_{dpc} + \Gamma_{div} = (N_s - 2) + 21 \times L \times I.$$

Fig. 2 shows the critical path of our spectrum sensor architecture and hence the critical delay responsible for maximum clock frequency is

$$\tau_{cr} = \tau_{CCM} + \tau_{8:1Mux} + \tau_{mul} + 3 \times \tau_{add} + \tau_{1:8Demux}.$$

III. PERFORMANCE ANALYSIS, VLSI DESIGN AND COMPARISON

In practical scenario, majority of real world signals are correlated and this section presents the performance analysis based on such signals. This analysis is carried out in AWGN channel environment.

We have considered noise variance (σ^2) of 1 for our MED based spectrum sensor design, as it is infeasible to compute actual σ^2 on-the-fly in hardware to obtain decision threshold. It has been already reported in literature that MED based spectrum sensing performs better than energy detection for highly correlated signals. On the other hand, we present the performance comparison of our MED based sensor with contemporary cyclostationary based spectrum sensor (CSS). In this simulations, 102 OFDM symbols which is around 4096 samples, with cyclic prefix of 8 and 32 subcarriers at 4 bits/symbol rate have been generated and transmitted through AWGN channel environment by adding noise with $\sigma^2=1$. Further, 2000 Monte-carlo simulation has been carried out to obtain the performance, as shown in Fig. 3. It clearly shows that the hardware efficient MED based spectrum sensor performs better than CSS by 4.5 dB at $P_d = 0.5$. Thus for highly correlated signals, proposed MED based spectrum sensor has better performance compared to energy detection based spectrum sensor and CSS. In addition, Fig. 3 shows that the suggested hardware-efficient MED based spectrum sensing algorithm delivers a minor degradation of 0.12 dB at P_d of 0.5 in comparison with the conventional MED based spectrum sensing algorithm.

V. CONCLUSION

This paper presented the spectrum sensor design for detecting the correlated signals for cognitive radio environment. Specifically, we intend to use this MED based spectrum sensor for accessing the TV white space in order to support various applications and alleviate the spectrum congestion problem. To the best of our knowledge, this paper has

International Journal of Innovative Research in Science, Engineering and Technology

(A High Impact Factor, Monthly, Peer Reviewed Journal)

Visit: www.ijirset.com

Vol. 9, Issue 3, March 2020

reported the first VLSI architecture for MED based spectrum sensing. It has proven to be most hardware efficient with fast sensing time in comparison with contemporary spectrum sensors.

REFERENCES

- [1] O. Ileri and N. B. Mandayam, "Dynamic spectrum access models: toward an engineering perspective in the spectrum debate," *IEEE Commun. Mag.*, vol. 46, pp. 153–160, Jan. 2008.
- [2] D. Cabric, I. D. O'Donnell, M. S.-W. Chen, and R. W. Brodersen, "Spectrum sharing radios," *IEEE Circuits Syst. Mag.*, vol. 6, pp. 30–45, 2006.
- [3] C. Nagarajan and M. Madheswaran - 'Stability Analysis of Series Parallel Resonant Converter with Fuzzy Logic Controller Using State Space Techniques' - *Electric Power Components and Systems*, Vol.39 (8), pp.780-793, May 2011
- [4] K.B. letaief and W.Zhang, "Cooperative Communication for Cognitive radio networks," *Proc.IEEE*, Vol. 97, no.5, pp. 878-893, May 2009.
- [5] Iam F.Akyildiz*, Won-yeol Lee, Kaushik R.Chowdhury Broadband wireless Networking Laboratory, School of Electrical and computer Engineering, Georgia Institute of Technology, Atlanta, GA 30332, United States.
- [6] S.Haykin, Cognitive radio: brain-empowered wireless communications, *IEEE journal on selected areas in communications*, 23 (2) (2005) 201-220.
- [7] E Geetha, C Nagarajan, "Induction Motor Fault Detection and Classification Using Current Signature Analysis Technique", 2018 Conference on Emerging Devices and Smart Systems (ICEDSS), 2nd and 3rd March 2018, organized by mahendra Engineering College, Mallasamudram, PP. 48-52, 2018
- [8] H. K. Anabi, R. Nordin, O. B. Abdulghafoor et al. "From Sensing to Predictions and Database Technique: A Review of TV White Space Information Acquisition in Cognitive Radio Networks," *Wireless Pers Commun.*, 96: 6473, 2017.
- [9] M. Kosunen, V. Turunen, K. Kokkinen, and J. Rynnänen, "Survey and analysis of cyclostationary signal detector implementations on FPGA," *IEEE J. Emerg. Sel. Topics Circuits Syst.*, vol. 3, no. 4, pp. 541-551, Dec. 2013.
- [10] V. Khatri and G. Banerjee, "A 0.25-3.25-GHz wideband CMOS-RF spectrum sensor for narrowband energy detection," *IEEE Trans. Very Large Scale Integr. (VLSI)*, vol. 24, no. 9, pp. 2887-2898, Sep. 2016.
- [11] C. Nagarajan, M. Madheswaran and D. Ramasubramanian - 'Development of DSP based Robust Control Method for General Resonant Converter Topologies using Transfer Function Model' - *Acta Electrotechnica et Informatica Journal*, Vol.13 (2), pp.18-31, April-June.2013
- [12] R. K. Sharma, A. Lavrenko and R. S. Thoma, "Performance Evaluation of Energy Detection for Correlated Random Signals," *IEEE 77th Vehicular Technology Conference (VTC Spring)*, pp. 1-5., 2013.
- [13] M. S. Murty and R. Shrestha, "Reconfigurable & Memory-Efficient Cyclostationary Spectrum Sensor for Cognitive-Radio Wireless Networks," *IEEE Trans. Circuits Syst. II, Exp. Briefs*, vol. 65, no. 8, pp. 1039-1043, Aug. 2018.
- [14] Y. Zeng, C. L. Koh, and Y. Liang, "Maximum eigenvalue detection: theory and application," *IEEE International Conference on Communications, Beijing*, pp. 4160-4164, May-2008.
- [15] S. M. Safavi and M. Shabany, "A VLSI architecture for multiple antenna eigenvalue-based spectrum sensing," *19th IEEE International Conference on Electronics, Circuits, and Systems (ICECS 2012)*, pp. 153-156, Dec-2012.
- [16] S. M. Safavi and M. Shabany, "A real-time, low-power implementation for high-resolution eigenvalue-based spectrum sensing," *Analog Integrated Circuits and Signal Processing - Springer*, pp. 437-447, Dec-201
- [17] M. T. Masonta, M. Mzyece and N. Ntlatlala, "Spectrum Decision in Cognitive Radio Networks: A Survey," in *IEEE Communications Surveys*
- [18] Bravo, Ignacio, Pedro Jimenez, Manuel Mazo, Jos'e Luis L'azaro, and Alfredo Gardel. "Implementation in FPGAs of Jacobi method to solve the eigenvalue and eigenvector problem." In *Field Programmable Logic and Applications, 2006. FPL'06. International Conference on*, pp. 1-4. IEEE, 2006.
- [19] Saad, Yousef. Numerical methods for large eigenvalue problems: revised edition. Vol. 66. Siam, 2011.